

Flat Pattern view
SCALE: 1:2

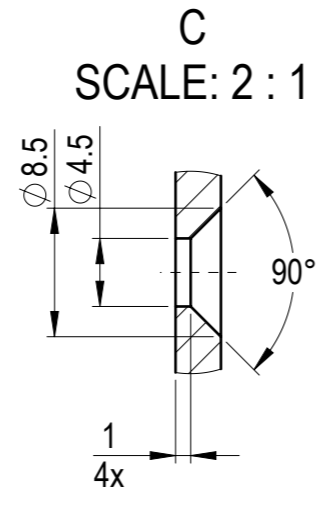
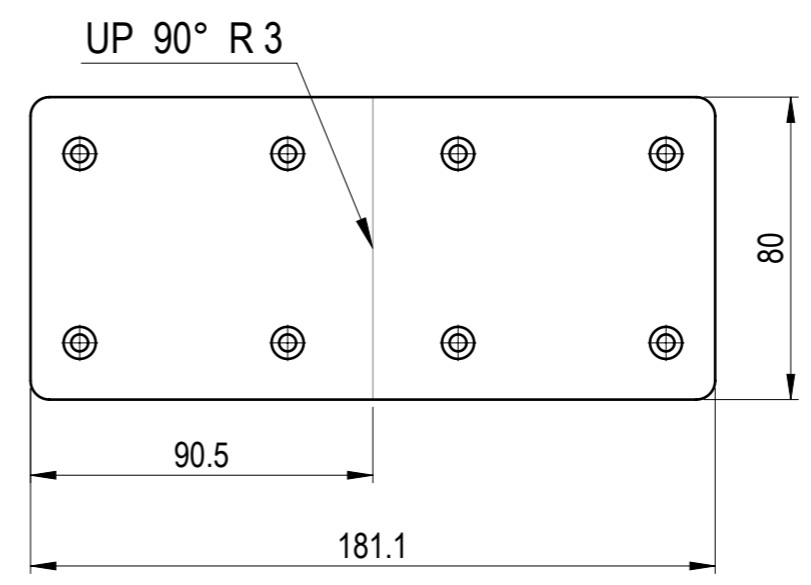

Other dimensions from .DXF file.

| SHEET METAL INFORMATION | |
|-------------------------|-------|
| Length, mm | 181.1 |
| Width, mm | 80 |
| Thickness, mm | 3 |
| Inside Bend Radius, mm | 3 |
| K-Factor | 0.5 |
| No. of Bends | 1 |

| | | | | | | | |
|--------------------------------------|--------------------|-----------------|-------------|--------------|------------------------------|------------|-----------|
| WEMPS ENGINEERING SERVICES | MATERIAL | S355JR | WEIGHT | 0.335 Kg | DEBURR AND BREAK SHARP EDGES | REVISION | DATE |
| | SURFACE PROTECTION | HDG EN ISO 1461 | MACHINING | ISO 2768 mK | THERMAL CUTTING | WELDING | SCALE |
| | NAME | SIGNATURE | PART NO. | 105-11311-01 | | 21.03.2025 | |
| Designed by | E. Kamols | | DESCRIPTION | Bent plate | | SCALE | FORMAT |
| Drawn by | E. Kamols | | | | | 1:2 | A3 |
| Technical ref. | | | | | | | SHEET 1/1 |